

Four Wave Mixing In DWDM Optical System

Gouri Deshmukh¹, Prof.Santosh Jagtap²

¹(Vidyalankar Institute Of Technology, Electronics and Telecommunication Engineering)
²(Vidyalankar Institute Of Technology, Electronics and Telecommunication Engineering)

ABSTRACT:

Optical nonlinearities give rise to many ubiquitous effects in optical fibres'. These effects are interesting in themselves and can be detrimental in optical communication. In the Dense Wave length division multiplexing system (DWDM) the nonlinear effects plays important role .DWDM system offers component reliability, system availability and system margin. DWDM system carries different channels. Hence power level carried by fiber increases which generates nonlinear effect such as SPM, XPM, SRS, SBS and FWM. Four wave mixing (FWM) is one of the most troubling issues. The FWM gives crosstalk in DWDM system whose channel spacing is narrow. By using the fiber with proper amount of dispersion and by unequal spacing between channels it is possible to suppress FWM crosstalk. In this paper the effect of FWM on optical system is considered and different techniques are compared to suppress FWM. Also optical spectrum and eye diagrams are observed for various dispersion and equal or unequal spacing at attenuation 0.2 dB, power 0.2 mW and wavelength 1550 nm.

KEYWORDS: FWM, DWDM system, channel spacing, Optical spectrum, cross phase modulation

I. INTRODUCTION

1.1 Optical Nonlinearities

One of the unique characteristics of optical fibres' is their relatively low threshold for nonlinear effects. This can be a serious disadvantage in optical communications, especially in dense wavelength-division multiplexing (DWDM) systems, where many closely spaced channels propagate simultaneously, resulting in high optical intensities in the fibre [1]. For instance, in a typical commercial 128-channel 10-Gb system, optical nonlinearities limit the power per channel to approximately -5 dBm for a total launched power of 16 dBm. Beyond this power level, optical nonlinearities can significantly degrade the information capacity of the system .On the other hand, optical nonlinearities can be very useful for a number of applications, starting with distributed in-fibre amplification and extending to many other functions, such as wavelength conversion, multiplexing and demultiplexing, pulse regeneration, optical monitoring, and switching. In fact, the development of the next generation of optical communication networks is likely to rely strongly on fibre nonlinearities in order to implement all-optical functionalities. The realization of these new networks will therefore require that one look at the trade off between the advantages and disadvantages of nonlinear effects in order to utilize their potential to the fullest.

The nonlinear interactions in optical fibres depend on the transmission length and the cross-sectional area of the fibre as shown in equation 1. The longer the link length, the more the interaction and the worse the effect of nonlinearity[3].

$$L_{\epsilon} = \frac{1 - e^{-\alpha L}}{\alpha} \quad (1)$$

Where L_{ϵ} is effective length, L is link length and α is attenuation constant.

1.2 Types of Optical Nonlinearities

There are two types of nonlinearities one is scattering phenomenon that arise from scattering that are stimulated Brillouin scattering (SBS) and stimulated Raman scattering (SRS). Another is refractive index phenomenon that arise from optically induced changes in the refractive index, and result either in phase modulation [self-phase modulation (SPM) and cross phase modulation (XPM)] or in the mixing of several

waves and the generation of new frequencies [modulation instability (MI) and parametric processes, such as four wave Mixing (FWM)][4].

1.2.1 Scattering Phenomenon

In stimulated Brillouin scattering (SBS) the phonons are acoustic phonons. Pump and Stokes waves propagate in opposite directions. It does not typically cause interaction between different wavelengths. It creates distortion in a single channel and depletes the transmitted signal. The opposite traveling Stokes wave means the transmitter needs an isolator.

If two or more signals at different wavelengths are injected into a fiber, Stimulated Raman Scattering (SRS) causes power to be transferred from the lower wavelength channels to the higher-wavelength channels. It has a broadband effect (unlike SBS). In SRS there are both forward and reverse traveling Stokes waves. SRS causes a signal wavelength to behave as a "pump" for longer wavelengths, either other signal channels or spontaneously scattered Raman-shifted light. The shorter wavelengths are attenuated by this process, which amplifies longer wavelengths. SRS takes place in the transmission fiber.

1.2.2 Refractive Index Phenomenon

In self phase modulation (SPM), the intensity modulation of an optical beam results in the modulation of its own phase via modulation of the refractive index of the medium. It is a phenomenon that leads to spectral broadening of optical pulses. SPM is the temporal analog of self-focusing. Cross Phase Modulation (XPM) is a similar effect to SPM, but it involves two optical beams instead of one. In XPM, the intensity modulation of one of the beams in a phase modulation of the other. However, because the total intensity is the square of a sum of two electric-field amplitudes, the spectral broadening caused by XPM is twice as large as in SPM.

1.3 Kerr Effect

It is a nonlinear interaction of light in a medium with an instantaneous response, related to the nonlinear electronic polarization. The Kerr effect is a nonlinear optical effect occurring when intense light propagates in crystals and glasses, but also in other media such as gases. [4].

II. FOUR WAVE MIXING

2.1 Basics of FWM

The interaction of two or more light waves can lead to a second kind of χ (3) nonlinearities. These involve an energy transfer between waves and not simply a modulation of the index seen by one of them due to the other. This interaction is often referred to as "parametric," and these nonlinearities lead to parametric processes. Four wave mixing (FWM) is one of the most troubling issues. Three signals combine to form a *fourth* spurious or mixing component, hence the name four wave mixing, shown in Figure 1 in terms of frequency ω :

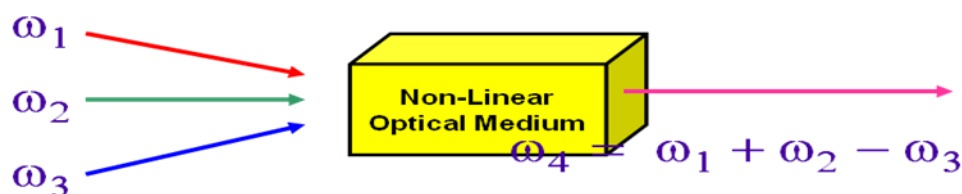

Figure 1 Formation of Fourth Spurious Component

Four-wave mixing transfers' energy from a strong pump wave to two waves up shifted and downshifted in frequency from the pump frequency ω_1 . If only the pump wave is incident at the fibre, and the phase-matching condition is satisfied, the Stokes and anti-Stokes waves at the frequencies ω_3 and ω_4 can be generated from noise. On the other hand, if a weak signal at ω_3 is also launched into the fibre together with the pump, the signal is amplified while a new wave at ω_4 is generated simultaneously. The gain responsible for such amplification is called the parametric gain [4].

2.2 Effects of FWM

Four wave mixing (FWM) is one of the most troubling issues. Three signals combine to form a *fourth* spurious or mixing component, hence the name four wave mixing. Spurious components cause following problems:

- Interference between wanted signal(cross)
- It generates additional noise and degrades system performance
- Power is lost from wanted signals into unwanted spurious signals

The total number of mixing components increases dramatically with the number of channels. The total number of mixing components, M is calculated from the equation 2.

$$M = (\frac{1}{2}) N^2 (N-1) \quad (2)$$

Thus three channels create 9 additional signals and so on. As N increases, M increases rapidly. Where N is no. of channels.

2.3 Effect of Dispersion and Channel Spacing on FWM

As dispersion increases effect of four wave mixing decreases. For dispersion 16ps/nm FWM effect reduces but chromatic dispersion increases. At zero dispersion FWM effect more hence fiber having dispersion 4ps/nm is used where FWM effect is less and fiber is called Non-Zero dispersion shifted fiber. Due to equal spacing some FWM components overlap DWDM channels. But in unequal spacing there is no overlapping of DWDM channels and wavelength conversion occurs.

2.4 Minimization of FWM Effects

Traditional non-multiplexed systems have used dispersion shifted fiber at 1550nm to reduce chromatic dispersion. Unfortunately operating at the dispersion minimum increases the level of FWM. Conventional fiber (dispersion minimum at 1330 nm) suffers less from FWM but chromatic dispersion rises. Solution is to use "Non-Zero Dispersion Shifted Fiber" (NZ DSF), a compromise between DSF and conventional fiber (NDSF, Non-DSF). ITU-T standard is G.655 for non-zero dispersion shifted single mode fibers. By using unequal spacing between DWDM channels effect of FWM decreases.

III. EXPERIMENTAL SETUP AND SIMULATION

Experimental set up shown in Figure 2 consists of two channels DWDM system. This consists of laser sources, pulse generator and NRZ converters. Optical scope is connected to observe optical spectrum and electroscope is for eye diagram. And this is simulated by using optsim software. Wavelength of sources is set to 1550 nm and dispersion is varied from 0 to 4 ps/nm/km and optical spectrum is observed.

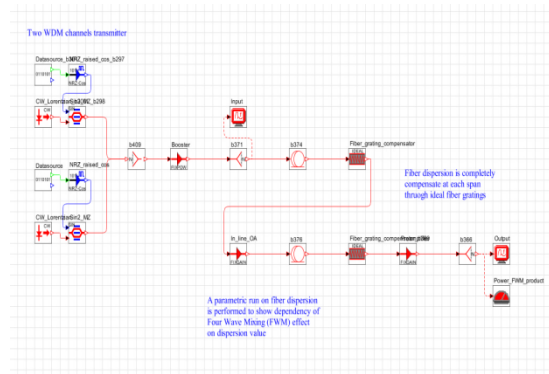

Figure 2 Two Channel DWDM System

Experimental set up shown in Figure 3 consists of four channels DWDM system. Each channel is set to central wavelength 1550nm firstly for equal channel spacing of 0.2nm and then unequal spacing of 0.1, 0.2, 0.1, 0.2 nm respectively. Optical spectrum and eye diagram are observed for equal and unequal spacing keeping dispersion constant.

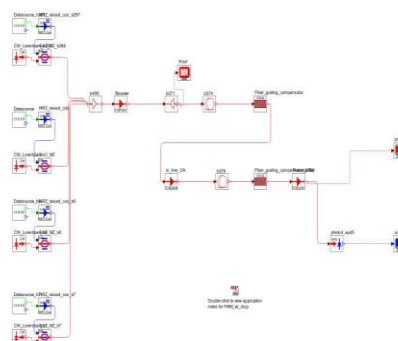

Figure 3 Four Channel DWDM System

IV. RESULTS AND DISCUSSION

By varying the dispersion from 0 to 4 ps/nm/km we observed effect of dispersion on FWM. And also effect equal and unequal spacing on FWM is observed. These effects are shown in following figs.

4.1 Effect of Dispersion

At input when we apply signal observed input optical spectrum as shown in Figure 4. By varying dispersion we observed the effects.

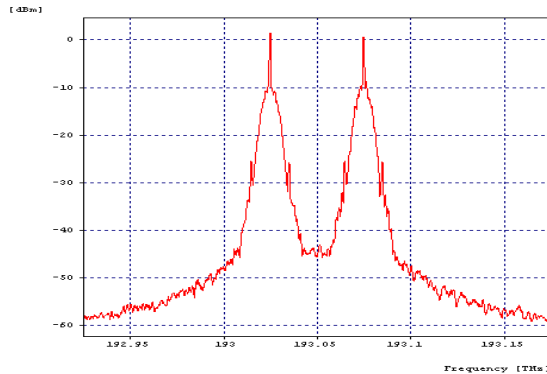

Figure 4 Input Spectrum

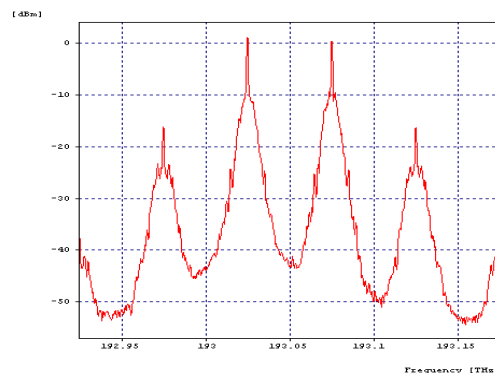

Figure 5 Output spectrum dispersion=0

Fig. 5 shows at zero dispersion FWM effect is more i.e. -15dB and as dispersion increases FWM effect decreases. It is -25dB and -32dB as shown in Figure 6 and Figure 7 respectively.

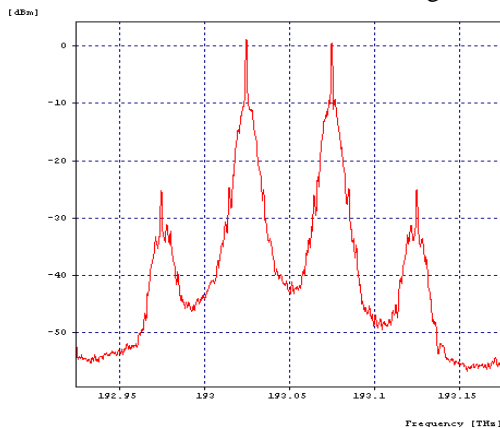

Figure 6 Output spectrum dispersion=1

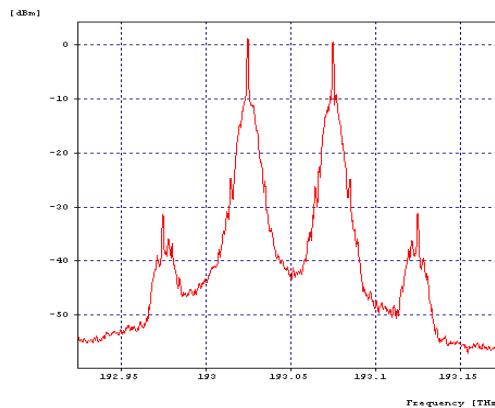

Figure 7 Output spectrum dispersion=2

Further as dispersion is 3 ps/nm/km and 4 ps/nm/km effect of FWM decreases. It is -33dB and -36 dB as shown in Figure 8 and Figure 9 respectively.

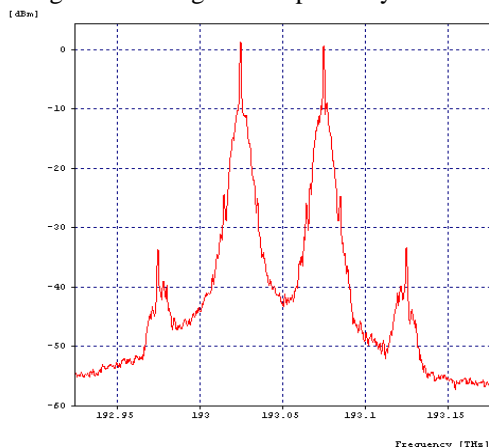

Figure 8 Output spectrum dispersion=3

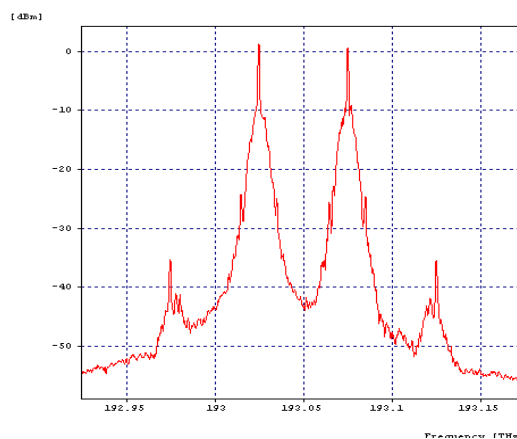

Figure 9 Output spectrum dispersion=4

4.2 Effect of Channel Spacing

Figure 10 shows Optical spectrum and Figure 11 shows eye spectrum for equal spacing of 0.2 nm.

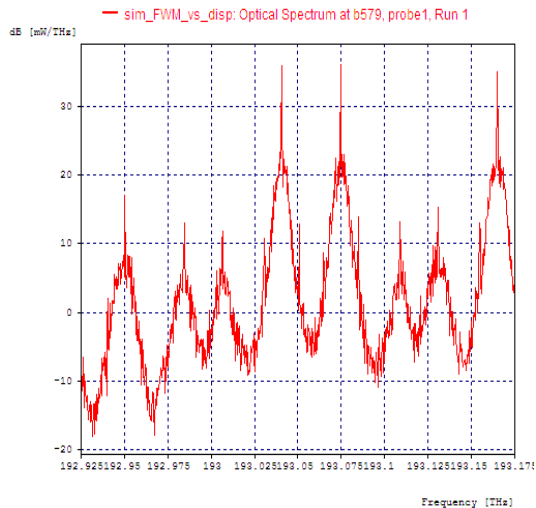

Figure 10 Optical spectrum

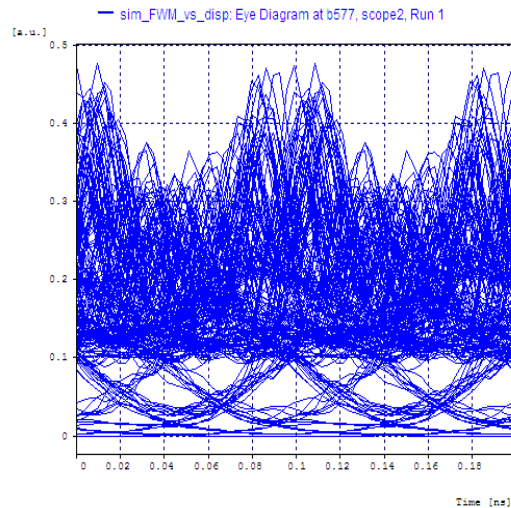

Figure 11 Eye spectrum

As shown in fig 11 eye spectrum is distorted. For equal spacing effect of FWM is more. But for unequal spacing effect of FWM decreases. For this spacings are 0.1, 0.2, 0.1 and 0.2 nm. Figure 12 and Figure 13 show effect of unequal spacing.

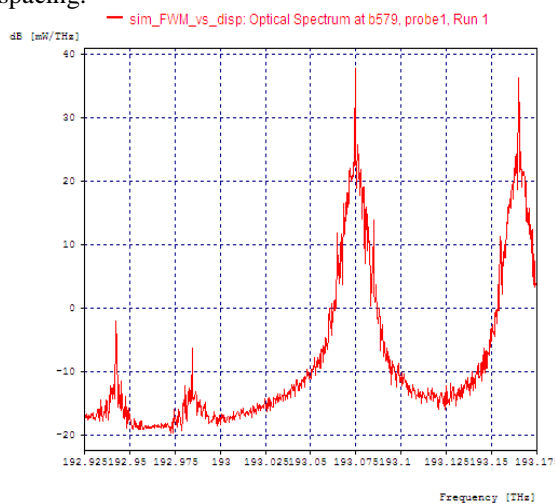

Figure 12 Optical spectrum

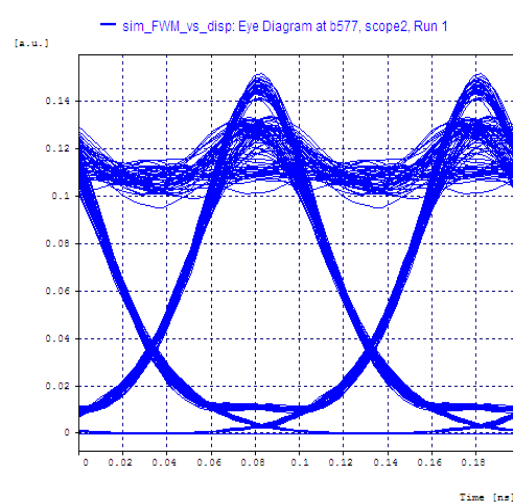

Figure 13 Eye spectrum

V. CONCLUSION

FWM leads to interchannel crosstalk in DWDM systems. It generates additional noise and degrades system performance. By using non zero dispersion shifted fiber i.e. fiber having 4 ps/nm/km and using unequal spacing among channels FWM effect can be reduced. On other hand FWM can be used beneficially for parametric amplification, demultiplexing of OTDM channels, wavelength conversion of WDM channels.

REFERENCES

- [1] Moncef B.Tayahi*, Sivakumar Lanka, Banmali Rawat, Four Wave Mixing in Closely Spaced DWDM Optical Channels, International Journal of Microwave and Optical Technology, vol.1, No.2, August 2006.
- [2] J. Toulouse, Optical Nonlinearities in Fibers: Review, Recent Examples, and Systems Applications, Journal of Light Wave Technology, Vol. 23, No. 11, November 2005.
- [3] L. G. L. Wegener, M. L. Povinelli, A. G. Green, P. P. Mitra, J. B. Stark, P. B. Littlewood, The effect of propagating nonlinearities on the information capacity of WDM optical fiber systems: Cross-phase modulation and four-wave mixing, Physica, D, vol. 189, no. 1–2, pp. 81–99, Feb. 15, 2004.
- [4] G. P. Agrawal, Nonlinear Fiber Optics, 2nd ed. (San Diego, CA: Academic, 1995).
- [5] G. P. Agrawal, Nonlinear Fiber Optics, 3rd ed. (San Diego, CA: Academic, 2001).
- [6] G. P. Agrawal, Applications of Nonlinear Fiber Optics, (San Diego, CA: Academic, 2001).
- [7] Introducing DWDM http://www.cisco.com/univercd/cc/td/doc/product/mels/dwdm/dwdm_fns.htm